

# For Residential and Commercial Applications

Job Name \_\_\_\_\_  
Job Location \_\_\_\_\_  
Engineer \_\_\_\_\_  
Approval \_\_\_\_\_

Contractor \_\_\_\_\_  
Approval \_\_\_\_\_  
Contractor's P.O. No. \_\_\_\_\_  
Representative \_\_\_\_\_

## Series:

### Kitchen Cleaning Water Hose Reel (3/8" X 52.4 ft) With Spray Wand (16 meter)

C8269SW

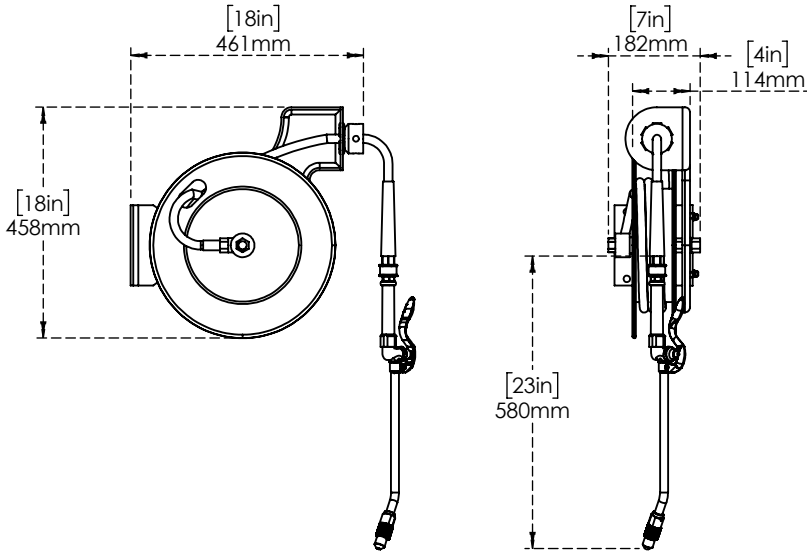

## Specification:

- Hose Reel is 16m long and made of great quality rubber for Heavy-duty use.
- Hose Reel Body is constructed from Powder Coated steel
- Ideal for food-service, Commercial Kitchens, Restaurants, & Hotel Applications.
- wall mount.
- Hose OD 3/8" is suitable to sustain high pressure of 300 PSI
- Hose Length 16 Meters

## Features & Benefits:

- This product is made with high quality and very resistant materials
- It is advisable for the hose to be installed near a source of water
- The most appropriate place is on a wall in horizontal position,
- Both for indoor and outdoor use

## Optional Hose Reel Spray Valves

- Spray Valve
- Trigger Water Gun

## Performance Data:

- Pressure: 20 - 125 psi [1.38 - 8.62 bar]
- Temperature: 40 F - 140 F [4.44 C - 60 C]
- Flow Rate: 4.20 GPM

## Product Compliance:

- California proposition 65

## Warranty: Two Years (Limited)

### NOTICE

The information contained herein is not intended to replace the full product installation and safety information available or the experience of a trained product installer. You are required to thoroughly read all installation instructions and product safety information before beginning the installation of this product.



US & Canada :- +1-678 666 2001

Krome product Specifications in U.S. customary units and metric are approximate and are provided for reference only. For precise measurements, please contact Krome Technical Service. Krome reserves the right to change or modify product design, construction, specifications, or materials without prior notice and without incurring any obligation to make such changes and modifications on Krome products previously or subsequently sold. For most updated specification sheet, go to