

# For Residential and Commercial Applications

Job Name \_\_\_\_\_  
Job Location \_\_\_\_\_  
Engineer \_\_\_\_\_  
Approval \_\_\_\_\_

Contractor \_\_\_\_\_  
Approval \_\_\_\_\_  
Contractor's P.O. No. \_\_\_\_\_  
Representative \_\_\_\_\_

## Series:

### 304 Stainless Steel Hose Reel - 50 Feet With Spray Valve

C8289SV

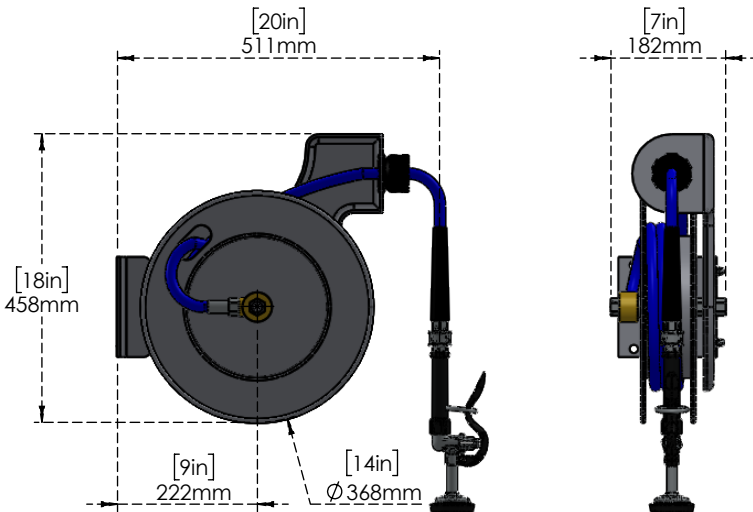

#### Features & Benefits:

- This product is made with 304 Stainless Steel
- It is advisable for the hose to be installed near a source of water
- The most appropriate place is on a wall in horizontal position,
- Both for indoor and outdoor use
- Retract automatically

#### Specification:

- Hose Reel is 15meter long and made of great quality rubber for Heavy-duty use.
- Ideal for food-service, Commercial Kitchens, Restaurants, & Hotel Applications.
- wall mount
- Hose OD 3/8" is suitable to sustain high pressure of 300 PSI
- Spray Valve Included

#### Optional Hose Reel Spray Valves

- Extended Spray Wand
- Trigger Water Gun

#### Product Compliance:

- California proposition 65

#### Warranty: One Years (Limited)

#### NOTICE

The information contained herein is not intended to replace the full product installation and safety information available or the experience of a trained product installer. You are required to thoroughly read all installation instructions and product safety information before beginning the installation of this product.



US & Canada :- +1-678 666 2001

Krome product Specifications in U.S. customary units and metric are approximate and are provided for reference only. For precise measurements, please contact Krome Technical Service. Krome reserves the right to change or modify product design, construction, specifications, or materials without prior notice and without incurring any obligation to make such changes and modifications on Krome products previously or subsequently sold. For most updated specification sheet, go to